

# MODEL 85B FOR FEEDING UP TO 420 TONS (378 MT) PER HOUR

The 85B, with a feed rate of 420 tons (378 mt) per hour, provides high capacity in a compact size. With its wide flat tray it can easily handle big bulky chunks such as rocks, coal and other mined materials. Capacity is based on 36 x 48 inch (914 x 1219 mm) tray properly installed with skirtboards.

Power Supply	230V, 460V, or 575V 50–60 Cycles, Single Phase
Full Load Power Input	25 Amp at 230V
Shipping Weight	2400 lb. (1090 kg)

## SPECIFICATIONS

### 85B OVERHEAD-DRIVE STANDARD TRAYS

SIZE		A	B	C	D	E	F	G	H	J	K
18 x 84	in	18	84	27-5/8	19-3/4	40-1/8	87-1/8	86-1/8	38-1/8	17-1/2	23-1/4
	mm	457	2134	702	500	1019	2213	2189	968	444	589
24 x 72	in	24	72	32-1/2	15-3/4	34	81-7/16	74-5/16	35-3/4	12-15/16	15-1/4
	mm	610	1829	826	400	864	2069	1888	908	328	387
30 x 60	in	30	60	39-1/2	14-7/8	34-3/4	71-7/8	62-5/8	37-3/4	15-1/8	14-3/8
	mm	762	1524	1003	377	883	1827	1590	958	384	365
36 x 48	in	36	48	45	12-3/4	32-3/4	60	50-3/4	40-1/4	15-7/8	17
	mm	914	1219	1142	324	832	1524	1289	1023	403	431

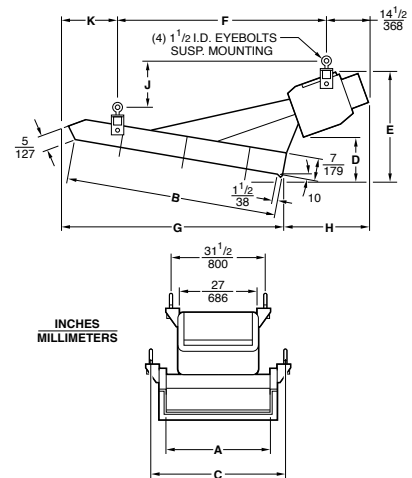

### 85B UNDER-DRIVE STANDARD TRAYS

SIZE		A	B	C	D	E	F	G	H	J	
18 x 84	in	18	84	27-5/8	10-1/8	31	17-3/8	62-7/8	7	65-3/4	
	mm	457	2134	702	257	786	442	1596	177	1659	
24 x 72	in	24	72	33-1/2	12-1/2	31-3/8	16-7/8	50-3/4	8	53	
	mm	610	1829	851	317	797	429	1288	203	1346	
30 x 60	in	30	60	39-5/8	10-5/8	27-3/8	20-3/4	39-7/8	8-1/2	42-7/8	
	mm	763	1524	1008	271	695	528	1013	217	1088	
36 x 48	in	36	48	45-5/8	11	25-7/8	24-1/4	39-3/8	7	42-1/4	
	mm	914	1219	1159	280	657	616	999	179	1072	
100 x 120 120 x 108 140 x 96 160 x 84		CONSULT HOME OFFICE									

